

Vesta is at my place project #2



Vesta is at my place

is a trademark of

Casa Valentina s.r.l.

via Ponte Gandovere 33

25064 Gussago (Brescia)

T +39 0302410269

F +39 0303730610

info@casavalentina.it

www.casavalentina.it

project #2:

progetto - coordinamento:

Alberto Zecchini

grafica:

Andrea Gualdi - Shipmate

fotografia:

Alberto Petrò

Russian Division

121357, Russia, Moscow

Nezhinskaya Street, 1 of.202

Kutuzovskaya Riviera

Tel.: +7 495 641 7495

Tel.: +7 9035308926

E-mail: casavalentina@mail.ru

E-mail: lamaz@mail.ru

Polish Division

SHOW ROOM CASA VALENTINA

UL. MACIEJKI 5

02181 WARSZAWA

Tel.: +48 (0)22 8460474

E-mail: warszawa@casavalentina.it

Vesta is at my place project #2







Vesta

- la nuova linea di Casa Valentina che prende il nome dalla dea romana protettrice della casa e dei suoi abitanti - **prosegue la sua esperienza con Project #2:**

“un sistema di elementi – apparentemente uguali – è dimensionato in modo da divenire supporti sia per tende a rullo, sia a scorrimento; una linea governata da geometria e semplicità, per un senso di ordine che, oltre a conferire eleganza, risulta pratico e discreto;” (G.A.)

“come le mensole delle murature - che nel linguaggio del costruire sono sporgenze ed aggetti che sorreggono parti esterne al muro - i materiali utilizzati sono il legno, la pietra (il marmo), il cemento e il metallo;” (M.G.)

“a scavalcare ogni schema riduttivo (un esempio per tutti vuole tende a scorrimento in ambienti abitativi e a rullo in quelli di lavoro) ecco un oggetto unico da utilizzarsi in ogni luogo e per differenti applicazioni: perché l’idea di “domesticità” si deve soprattutto nel ritrovarsi a proprio agio, anche grazie alla qualità e alla piacevole fruizione degli ambienti!” (L.B.)

Vesta

- the new Casa Valentina brand which takes its name from the Roman Goddess who protected houses and its inhabitants

- **continues his experience with Project #2:**

“a system of elements - apparently identical - is dimensioned as to become brackets for both roller blinds and sliding curtains; a line governed by the geometry and simplicity, giving a sense of order that is practical and discrete, always conferring elegance to the room;”
(G.A.)

“exactly like wall shelves – which, in the language of the building, are protrusions and projections that support other elements over the wall - the materials used are wood, stone (marble), concrete and metal;” (M.G.)

“to reverse any reductive pattern (a classical example wants the sliding curtains in residential houses and roller blinds in professional buildings) here is a single object to be used in all places and for different applications: because the idea of” domesticity “is mainly to feel comfortable, thanks also to the quality and leisurely enjoyment of the rooms! “
(L.B.)



RULLO A PARETE E A SOFFITTO

come le mensole delle murature, i materiali utilizzati sono il legno (rovere naturale e sbiancato), la pietra (marmo di carrara), il cemento (bianco e grigio) e il metallo (alluminio in diverse finiture);

Dai dizionari, i significati di "mensola":

"Costruttivamente si può dire mensola qualunque solido sporgente da una parete, assicurato a essa per incastro, e sottoposto nella sua parte libera a sollecitazioni di varia natura"

"(lat. "tàvolino) struttura orizzontale in aggetto: membratura incastrata o ancorata nella parete, ...a sostegno di arcate, archetti, architravi, balconi, colonnine, cornici, davanzali, gronde, oriel, ecc."

e talvolta anche di tende!!!

WALL OR CEILING ROLLER BLIND

exactly like wall shelves, the materials used are wood (natural and whitened oak), stone (Carrara marble), concrete (grey and white) and metal (aluminum in several finishes);

From dictionaries, the meaning of "shelf":

"a long, flat board fixed horizontally, usually against a wall or inside a cupboard so that objects can be stored on it"
(from the Cambridge Advanced Learners' Dictionary)

"horizontal structure projecting: a molding stuck or anchored to the wall, [...] in support of arcades, arches, lintels, balconies, columns, cornices, window sills, eaves, oriel, etc..."

...and sometimes also curtains!!!



ALLUMINIO BIANCO
WHITE ALUMINUM



SOFFITTO
CEILING



PARETE
WALL

MARMO DI CARRARA
CARRARA MARBLE



SOFFITTO
CEILING



PARETE
WALL



**Vesta is
at my place
project #2**

RULLO A PARETE E A SOFFITTO
WALL OR CEILING ROLLER BLIND

MASSELLI DI LEGNO DI ROVERE
FINITURA NATURALE
SOLID OAK WOOD IN NATURAL COLOUR



SOFFITTO
CEILING



PARETE
WALL



PESO
BOTTOM BAR



ROVERE FINITURA NATURALE
OAK WOOD IN NATURAL COLOUR



ROVERE VENATURA BIANCA
OAK WOOD WHITE GRAIN

RULLO A PARETE mensola dimensione: 90 mm x 50 x 125



MARMO DI CARRARA
CARRARA MARBLE



CEMENTO GRIGIO
GREY CONCRETE



CEMENTO BIANCO
WHITE CONCRETE

WALL ROLLER BLIND brackets' dimensions 90 mm x 50 x 125

ALL. NERO BASE
BRIGHT ALUMINUM

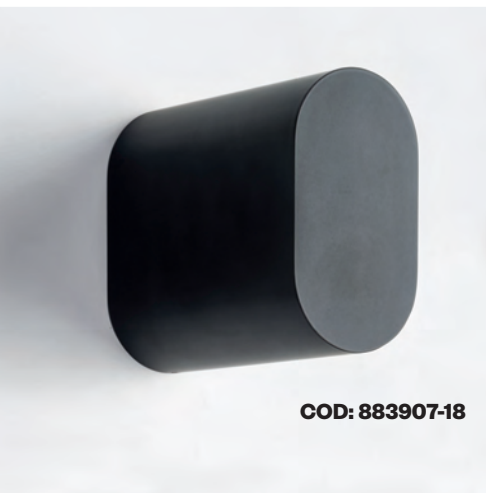

COD: 883907-18

COD: 883907-312



ALL. BIANCO OPACO
WHITE ALUMINUM

ALL. COLORE ACCIAIO SATINATO
ANODIZED ALL. STEEL COLOR



COD: 883907-25

COD: 883907-67

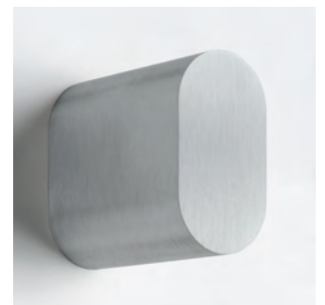

ALLUMINIO LUCIDO
BRIGHT ALUMINUM



RULLO A SOFFITTO mensola dimensione: 90 mm x 50 x 125



CEILING ROLLER BLIND brackets' dimensions 90 mm x 50 x 125

COD: 883907-312

COD: 883907-67



SCORRITENDA A PARETE

come le mensole delle murature, i materiali utilizzati sono il legno (rovere naturale e sbiancato), la pietra (marmo di carrara), il cemento (bianco e grigio) e il metallo (alluminio in diverse finiture);

Dai dizionari, i significati di "mensola":

Mensola: "...benché fossero già conosciute forme più arcaiche di mensola nel periodo Neolitico, tracce più consistenti le ritroviamo a partire dall'antichità classica, affermandosi soprattutto dal Medioevo in poi; nell'architettura militare storica, si usava una sorta di mensole; erano adibite al sostegno della merlatura e, contemporaneamente, alla realizzazione delle caditoie; questi elementi si chiamano propriamente beccatelli; nel periodo rinascimentale, la mensola inizia ad essere decorata da volute",

e nei nostri giorni anche da tende di ogni specie!!!

CURTAIN RAIL

exactly like wall shelves, the materials used are wood (natural and whitened oak), stone (Carrara marble), concrete (grey and white) and metal (aluminum in several finishes);

From dictionaries, the meaning of "shelf":

Shelf: "... although more archaic forms of the shelf in the Neolithic period were already known, more consistent traces can be found them starting from the Classical Age, establishing themselves mainly starting from the Middle Age on; in the Military historical architecture, a kind of shelves were used for supporting the battlements and, at the same time, for the realization of the drains; these elements are properly called corbels; during the Renaissance, the shelf begins to be decorated with scrolls, "

and even in our days by curtains of all kinds!!!







SCORRITENDA singolo a PARETE
WALL simple CURTAIN RAIL

Vesta is at my place project #2



MARMO DI CARRARA
CARRARA MARBLE



CEMENTO GRIGIO
GREY CONCRETE



ALL. NERO BASE
BLACK ALUMINUM



MASSELLI DI LEGNO DI ROVERE
FINITURA NATURALE
SOLID OAK WOOD IN NATURAL COLOUR



SCORRITENDA doppio a PARETE
WALL double CURTAIN RAIL

Vesta is
at my place
project #2



COD: 883219-18
883319-18

ALL. NERO BASE
BLACK ALUMINUM



COD: 883219-312
883319-312

ALL. BIANCO OPACO
WHITE ALUMINUM

ROVERE FINITURA NATURALE
OAK WOOD IN NATURAL COLOUR

SCORRITENDA A PARETE
mensola dimensione: 90 mm x 50 x 125

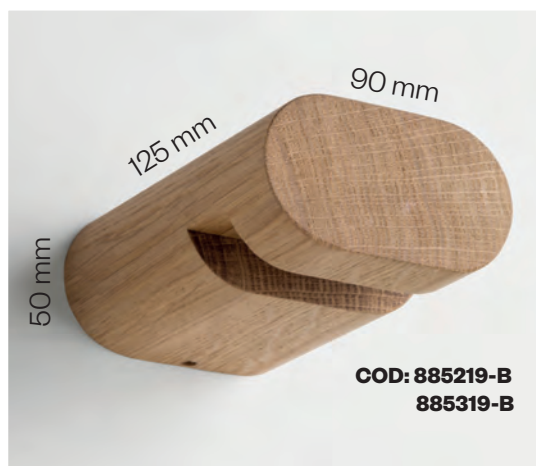

COD: 885219-B
885319-B

WALL MOUNTING CURTAIN RAIL
brackets' dimensions 90 mm x 50 x 125

ROVERE VENATURA BIANCA
OAK WOOD WHITE GRAIN



COD: 885219-V
885319-V

mensola dimensione::
90 mm x 50 x 190

ROVERE FINITURA NATURALE
OAK WOOD IN NATURAL COLOUR



COD: 885229-B
885329-B

ROVERE VENATURA BIANCA
OAK WOOD WHITE GRAIN



COD: 885229-V
885329-V



COD: 883219-25
883319-25

ALL. SATINATO
SATIN FINISHED ALUMINUM



COD: 883219-67
883319-67

ALL. LUCIDO
BRIGHT ALUMINUM

MARMO DI CARRARA
CARRARA MARBLE



COD: 888219-MC
888319-MC



COD: 887219-U
887319-U

CEMENTO GRIGIO
GREY CONCRETE



COD: 887219-J
887319-J

CEMENTO BIANCO
WHITE CONCRETE

brackets' dimensions:
90 mm x 50 x 190



ROVERE FINITURA NATURALE
OAK WOOD IN NATURAL COLOUR

COD: 885217-B
885317-B



ROVERE VENATURA BIANCA
OAK WOOD WHITE GRAIN

COD: 885217-V
885317-V



223110
Binario “adele”

dimensione: 22 x 22 mm

Rail “adele”

dimensions: 22 x 22 mm

COD: 223110-18



ALL. NERO BASE
 ALL. BASIC BLACK

COD: 223110-312



ALL. BIANCO OPACO
 ALL. MAT WHITE

COD: 223110-73



ALL. GRIGIO CEMENTO
 ALL. CONCRETE GREY

COD: 223110-99



ALL. BRONZO LUCIDO
 ALL. BRIGHT BRONZE

COD: 223110-25



ALL. COLORE ACCIAIO SATINATO
 ANODIZED ALL. STEEL COLOUR

COD: 223110-67



ALL. LUCIDO
 BRIGHT ALL.



COD: 313300-18

ALL. NERO BASE
ALL. BASIC BLACK



COD: 313300-312

ALL. BIANCO OPACO
ALL. MAT WHITE



COD: 313300-73

ALL. GRIGIO CEMENTO
ALL. CONCRETE GREY



COD: 313300-99

ALL. BRONZO LUCIDO
ALL. BRIGHT BRONZE



COD: 313300-25

ALL. COLORE ACCIAIO SATINATO
ANODIZED ALL. STEEL COLOUR



COD: 313300-67

ALL. LUCIDO
BRIGHT ALL.

313300 **Binario “marcella”**

dimensione: 30 x 15mm

Rail “marcella”

dimensions: 30 x 15 mm



MONTAGGI

MOUNTING PLAN

Rullo a parete
Wall roller blind

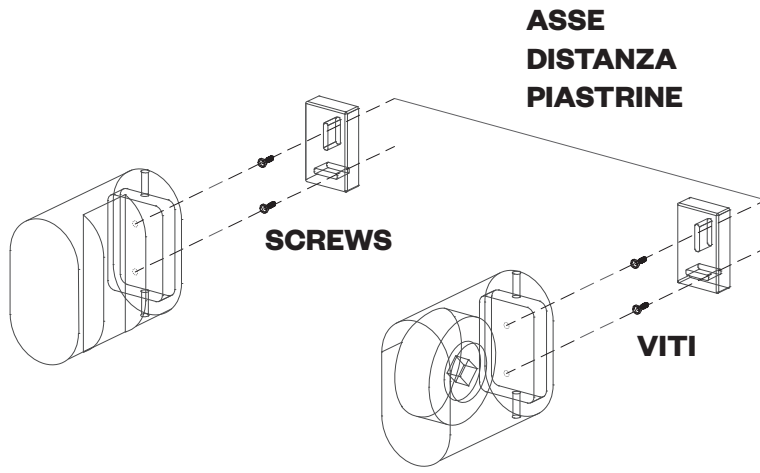

Rullo a soffitto
Ceiling roller blind

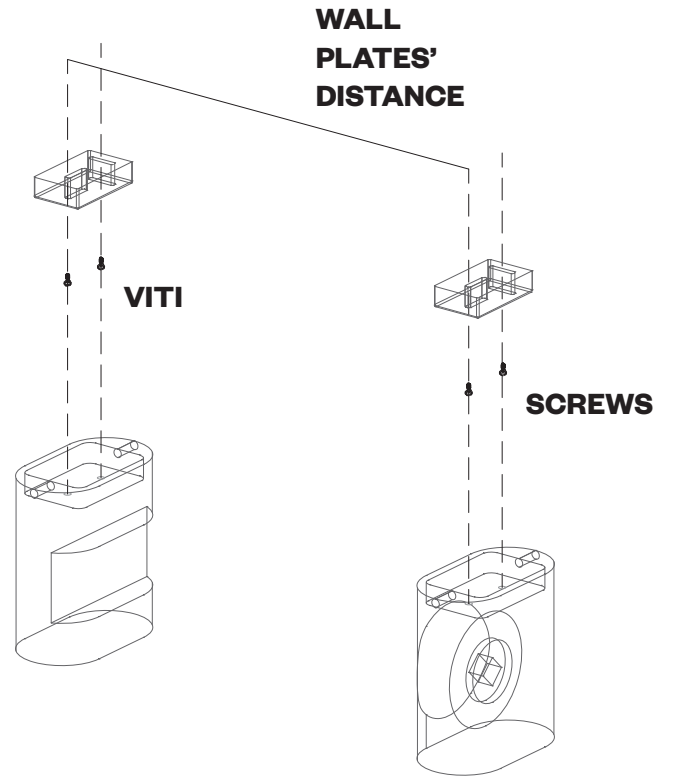

Scorritenda
Curtain rail

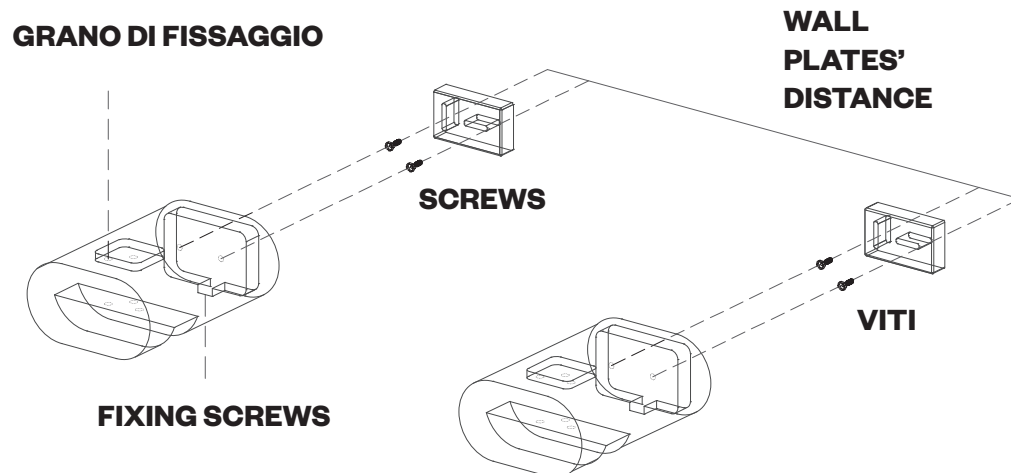

CONFIGURAZIONI SISTEMA SCORRITENDA

CURTAIN RAIL'S LAYOUTS

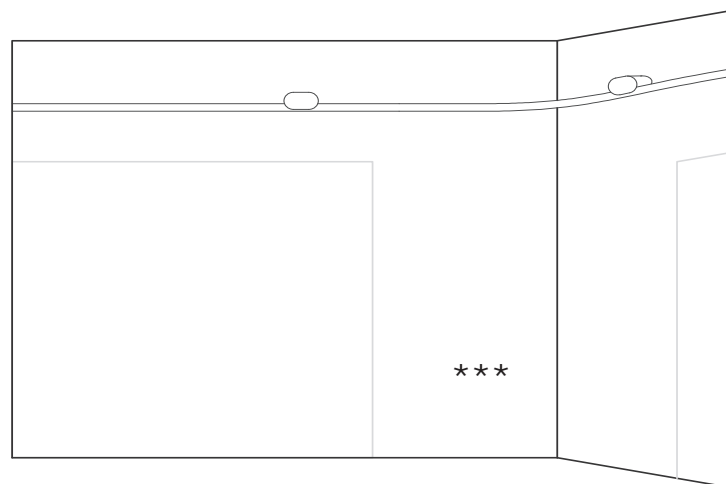
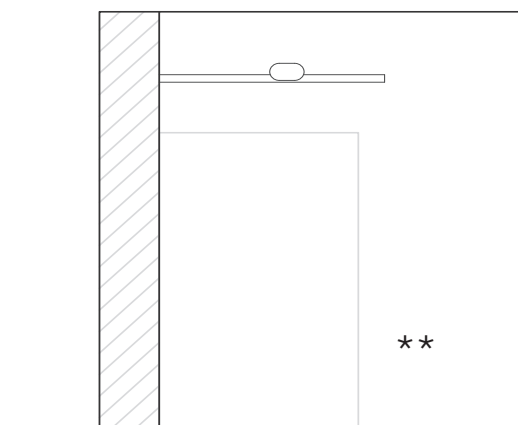
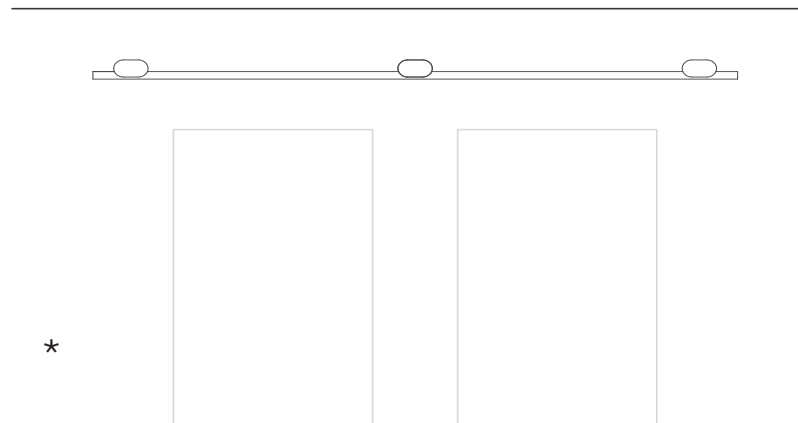
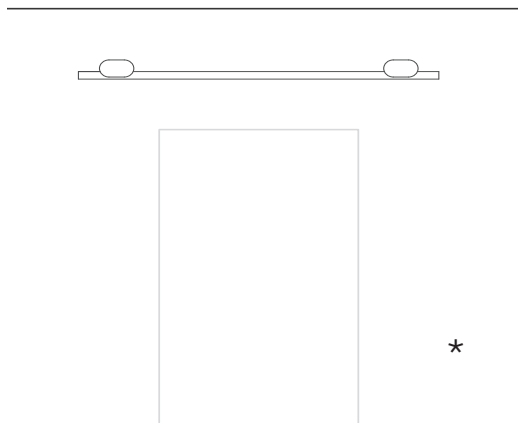

DIMENSIONI DIMENSIONS

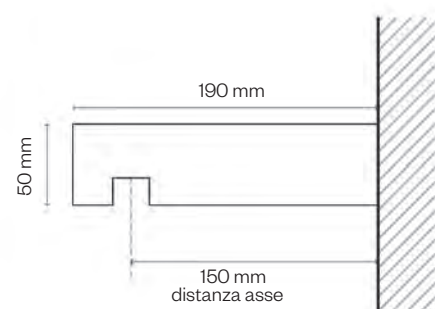
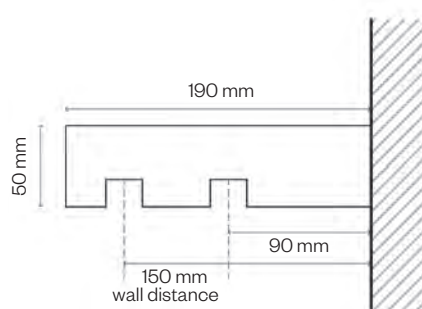
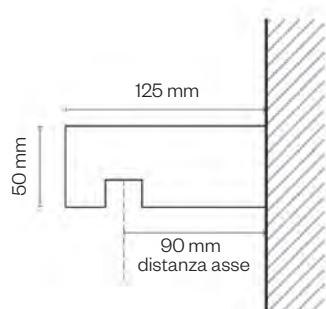
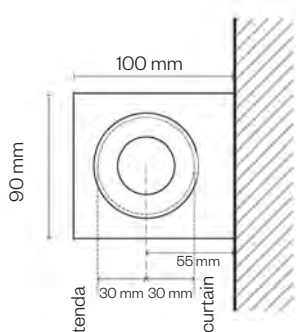

* misura personalizzabile

** misura da verificare con progetto

*** raggio min. 250 mm

* customizable dimension

** dimension to be confirmed on projects

*** minimum bending radius 10 inches

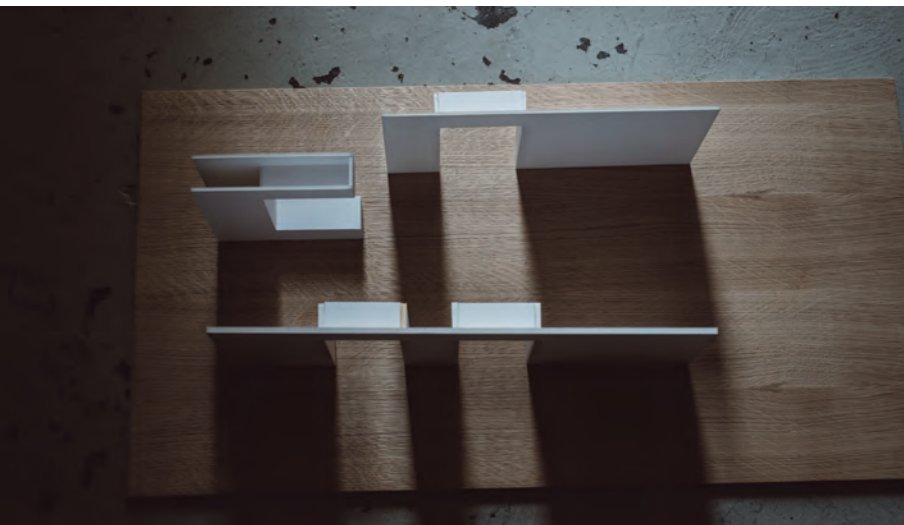

modello scala 1:20 set fotografico per **Vesta** project#2 giugno 2016





Vesta is at my place is a trademark of
Casa Valentina s.r.l. via Ponte Gandovere 33
25064 Gussago (Brescia)
T +39 0302410269 F +39 0303730610
info@casavalentina.it casavalentina.it

Russian Division
121357, Russia, Moscow
Nezhinskaya Street, 1 of:202
Kutuzovskaya Riviera
Tel.: +7 495 641 7495
Tel.: +7 9035308926
E-mail: casavalentina@mail.ru
E-mail: lamaz@mail.ru

Polish Division
SHOW ROOM CASA VALENTINA
UL. MACIEJKI 5
02181 WARSZAWA
Tel.: +48 (0)22 8460474
E-mail: warszawa@casavalentina.it